

YBS Insulation

HIGH QUALITY PRODUCTS FOR THE BUILDING INDUSTRY



CERTIFICATE NUMBER 157/11

(Therma-Close) **TYPE-R**

RIGID GENERAL PURPOSE CAVITY CLOSER SYSTEM



NOW AVAILABLE
FOR CHECK
REVEALS

Fits Cavities up to 300mm

NHBC Approved

Fully Certified

Fully Rigid Plastic Cavity Closer

Unique Secondary Water Seal for Frames

Ties in to both Leaves

Meets New Robust Details

Minimum Thermal Resistance 0.865m²k/w

(Therma-Close) **TYPE-R**

FIRE RETARDANT RIGID CAVITY CLOSER SYSTEM

FIRE-STOP



NOW AVAILABLE
FOR CHECK
REVEALS

Fire Integrity

60min up to 100mm

30min up to 150mm

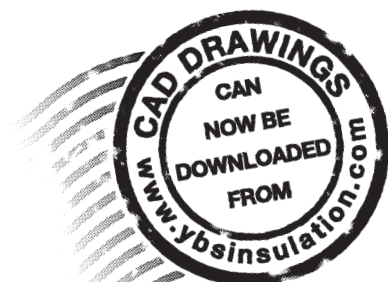

www.ybsinsulation.com

**PLEASE SPECIFY:
Insulated Cavity
Closer to be:**

YBS TYPE-R Length: 2.5m
**YBS TYPE-R
Fire Stop** Length: 1.2m

**Cavity Width: XXXmm
By: YBS Insulation**

(Therma-Close) **TYPE-R** and **Type-R Fire-Stop** are specially designed to create a more rigid waterproof cavity closer system.

TYPE-R and **Type-R Fire-Stop** comprise two rigid extensions, one of which has a unique, flexible, water seal. Once the window is in place the flexible seal sits against the window frame and acts as a secondary water seal.

These two rigid extensions allow **TYPE-R** and **Type-R Fire-Stop** to be made to any cavity width. **TYPE-R** and **Type-R Fire-Stop** are now available for both standard and check reveals to suit Robust Details.

**GWP Below 5
ODP Below 5**

(Therma-Close) **TYPE-R** **FIRE-STOP**

FIRE RETARDANT RIGID CAVITY CLOSER SYSTEM

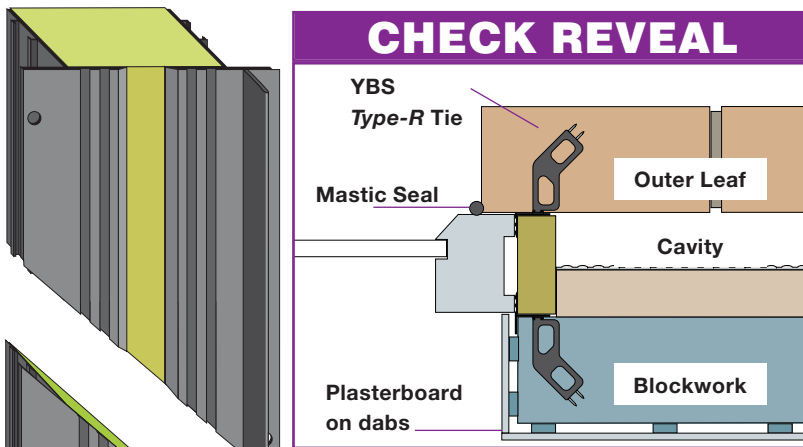

Jamb reveal vertical detail showing specially designed brick tie.

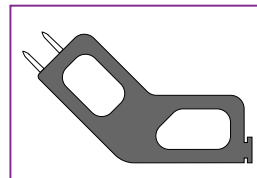

TYPE-R brick tie - supplied separately.

Features

- Waterproofing, Insulating and Self Locating in one fully assembled piece.
- **TYPE-R's** unique design incorporates a **flexible water seal** which reduces the possibility of water penetration. (in robust detail)
- Robust, easy to use on-site and can be cut to size and jointed, minimising waste.
- Eliminates the need for blockwork to close the cavity.
- Both are **CFC & HCFC Free** - kind to the environment.

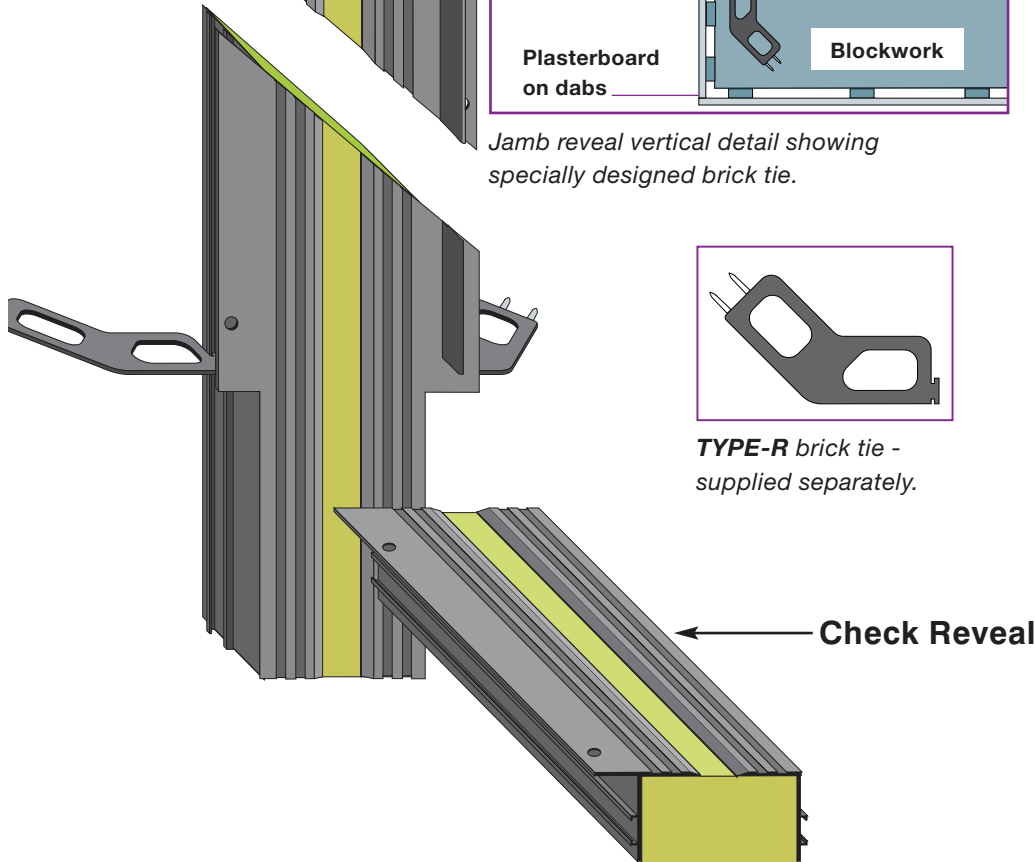

(Therma-Close) TYPE-R Fire-Stop is supplied in 1.2m lengths and can be supplied to suit any cavity width.

TYPE-R Fire-Stop is available for Robust and Check Reveals

COMPREHENSIVE FIXING DETAILS ARE AVAILABLE UPON REQUEST

YBS TYPE-R and **TYPE-R Fire-Stop** ties are also available to enable, if required, the closer to be built into both leaves. **TYPE-R** and **TYPE-R Fire-Stop** is designed to be used in door thresholds and both jambs and cills of windows, this provides a total solution to cold bridging problems associated with openings in traditional cavity wall construction.

Continual demand for greater thermal efficiency has lead to the reduction of the 'U' value requirements of structures, emphasised in the recent revision of Building Regulations (L1 & L2) and Building Standards Part J. **TYPE-R** and **TYPE-R Fire-Stop** are designed to offer the perfect solution for the specifier to satisfy this requirement.

The only rigid Cavity Closer available which creates a secondary water seal by use of a flexible strip. OR available for check reveal detail.

(Therma-Close) **TYPE-R**

RIGID GENERAL PURPOSE CAVITY CLOSER SYSTEM

Type-R can be installed in a variety of ways:

- Tack to window frame if built-in
- Built-in as work progresses using special ties (see fig. 2)
- **TYPE-R** can be installed after the reveal has been constructed by fixing to the inner leaf using holes provided.

Vertical Jointing

If required, sections of **(Therma-Close) TYPE-R** can be jointed to minimise waste. All joints must be tightly butted - 45° downwards towards the outer leaf. This will stop potential water penetration.

Corner Jointing

When jointing horizontal to vertical, trim both PCV flanges and allow the vertical to extend below the horizontal - this stops water ingress (see fig. 1).

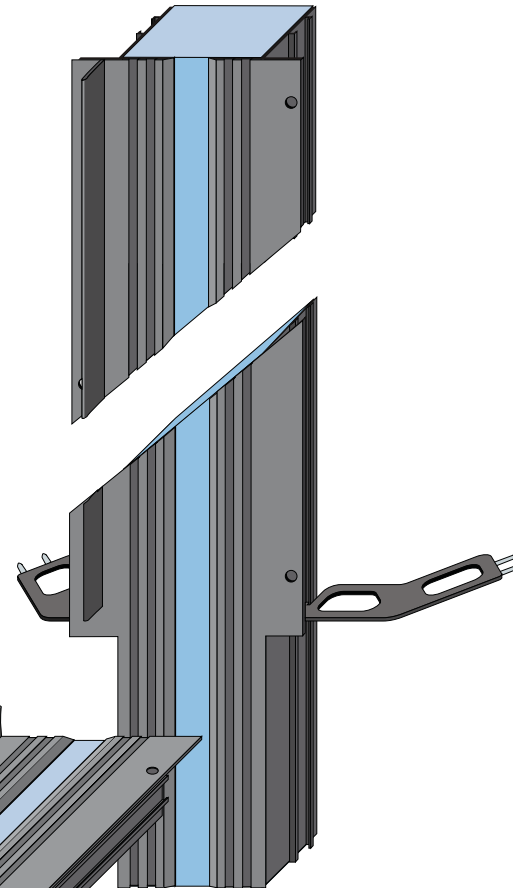

Horizontal to vertical jointing. Fig. 1

NB: The vertical section extends into the cavity.

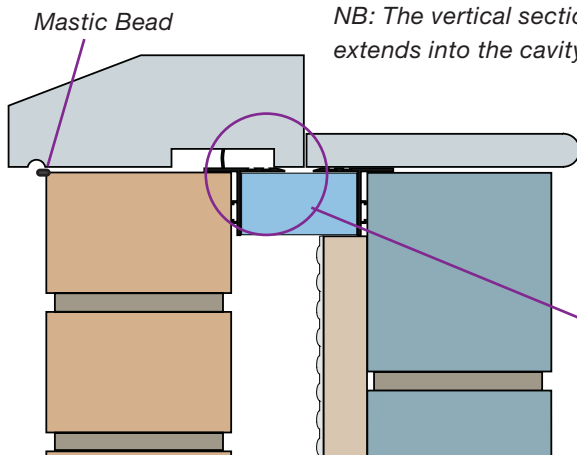

This detail shows how the flexible seal would prevent further water ingress if the mastic seal failed.

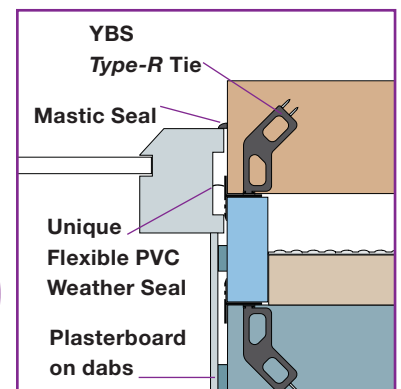
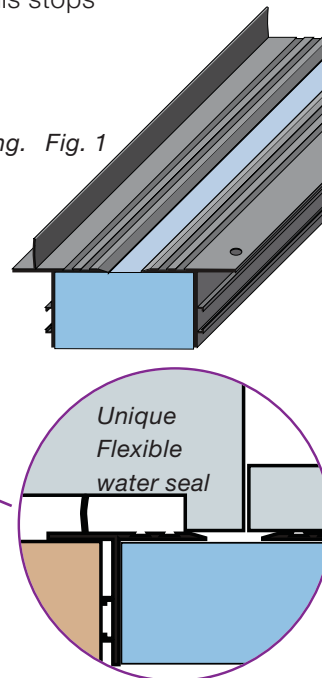

Jamb reveal vertical detail showing specially designed brick tie.

(Therma-Close) TYPE-R is supplied in 2.5m lengths and can be supplied to suit any cavity width.

(Therma-Close) TYPE-R is available for Robust and Check Reveals

For technical advice and support please call:

tel: 0844 99 100 44

e-mail: sales@ybsinsulation.com or fax: 0844 99 100 55

Technical Data

TOLERANCE

ALL FINISHED INSULATION SIZE TO HAVE A TOLERANCE OF -4MM TO +0MM TO SUIT VARYING CAVITY SIZES

Performance Test Data of Extrusion U-P.V.C./Plasticised - co-extruded under the control of a **Quality Assurance System**.

Performance Test Data of Insulation

X.P.S. (Extruded Polystyrene)

Thermal Conductivity 0.029 - 0.0335 W/mK

Mineral Fibre

Thermal Conductivity 0.034 W/mK

The diagrams below shows a window jamb in a masonry cavity wall, with **Type-R** and **Type-R Fire-Stop** closing the cavity. Robust details require a cavity closer with a minimum Thermal Resistance Path of 0.45m²K/W.

Example of Thermal Resistance for

Type-R Fire-Stop Check Reveal

The approach used to calculate the thermal resistance of its minimum thermal resistance path was in accordance with the guidance given in BRE IP 8/08. The minimum thermal resistance calculated for Type-R is 0.865m²k/w

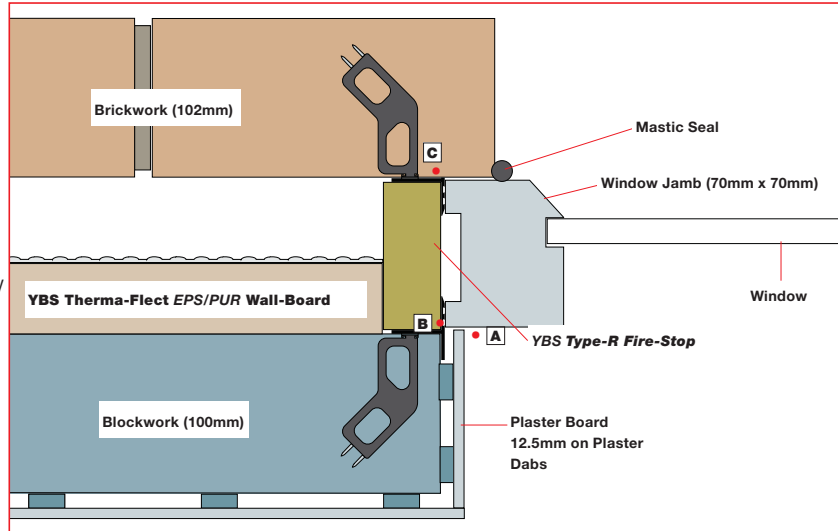

Technical References

Building Regulations 2006' Amended Approved Document L1A + L1B.

BRE publication "Thermal Insulation: Avoiding the risks".

TSO Publication: Limiting Thermal Bridging and Air Leakage : Robust Construction Details for Dwellings and Similar Buildings

BRE Scotland: Conventions for U Value Calculations

Example of Thermal Resistance for

Type-R Robust Details

The approach used to calculate the thermal resistance of its minimum thermal resistance path was in accordance with the guidance given in BRE IP 8/08. The minimum thermal resistance calculated for Type-R is 0.865m²k/w

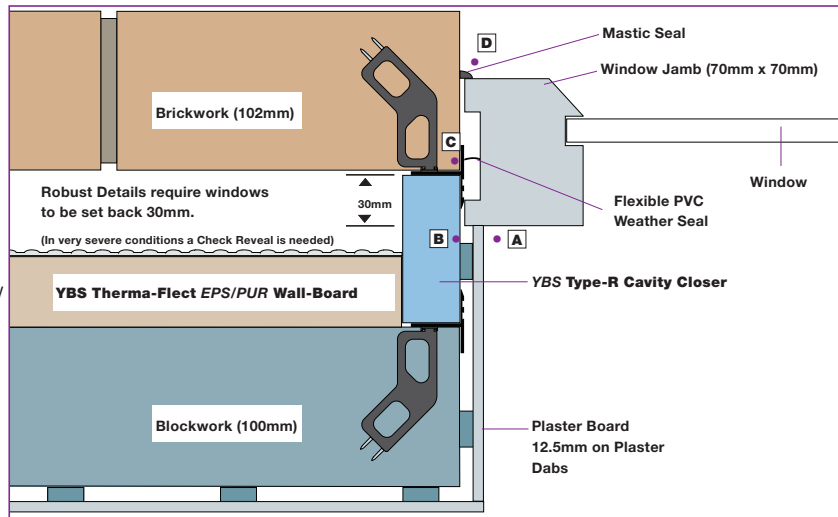

Yorkshire Building Services (WHITWELL) Ltd.
Craggs Industrial Park, Morven Street, Creswell, Derbyshire S80 4AJ
Tel: 0844 99 100 44 Fax: 0844 99 100 55

sales@ybsinsulation.com www.ybsinsulation.com